

A 40 GHz Communication Link With IF-Assisted Self-Heterodyne Direct Down Conversion

Marc DeVincentis, *Student Member, IEEE*, and Tatsuo Itoh, *Life Fellow, IEEE*

Electrical Engineering Department
University of California at Los Angeles
405 Hilgard Ave., Los Angeles, CA 90095-1594, U.S.A.
E-Mail: marcd@ee.ucla.edu



Abstract – A 40 GHz communication link was demonstrated using a combination of super-heterodyne mixing and self-heterodyne direct down conversion. The broadcast carrier and modulated signals inherent in self-heterodyne transmission were first mixed down from 40 GHz to an IF of 1.5 GHz using a 10.375 GHz LO and a novel, low LO power 4th harmonic diode mixer. These IF signals passed through an amplifier chain with a total gain of $G=75$ dB and noise figure of $NF=1.21$ dB prior to direct down conversion with a self-mixer. It was shown analytically and experimentally that the phase noise cancellation inherent in self-heterodyne detection is preserved independent of the phase noise of the additional LO signal. The input and output IF signals had the same phase noise up to 100 kHz carrier offset for a transmission distance of 2 meters.

I. INTRODUCTION

Most RF communication systems adopt a super-heterodyne receiver scheme, which requires a local oscillator (LO) at the receiver end to pump the mixer and down convert the RF signal. Additionally, in the case of suppressed-carrier digital modulation schemes, such as QPSK, a carrier recovery circuit is required. In millimeter wave transmission systems, it may be technically difficult to realize these system components. In particular, a stable local oscillator with very low phase noise is difficult to produce. These difficulties have sparked interest in self-heterodyne detection for millimeter wave systems. In the self-heterodyne method of detection, the transmitter broadcasts the carrier as well as the modulated signal containing the data. The baseband data is recovered by applying both received signals to a single mixer input. Since the carrier is transmitted along with the data, no local oscillator is needed in the receiver. Additionally, since the carrier is very close in frequency to the modulated data spectrum, the two signals remain almost exactly in phase at every point along the link. Therefore, the receiver does not require a carrier recovery circuit for coherent detection. In short, the self-heterodyne scheme can significantly reduce the circuit complexity of the receiver. This is especially useful for indoor wireless data distribution where there may be many receive terminals for a single broadcasting station, and the size and complexity of each receiver must be kept to a minimum. [1]

One of the most prominent shortcomings of the self-heterodyne system is the inherently low level of LO pumping power available to the mixer. [2] Classically, as in a super-heterodyne receiver, the input LO power is many orders of

magnitude greater than the received RF signal. A large LO swing can switch the mixer device across a wide range of current, generating maximum nonlinearity for efficient mixing. In a self-heterodyne system, the received carrier, which acts as the LO, will have a power level on the same order as the modulated signal since the transmitter power is limited and both signals experience the same free space loss. The low signal level of the input carrier ensures that the receiver mixer operates at low conversion efficiency. To overcome this problem, an LNA is typically required at the front end of the receiver, immediately before the baseband down conversion mixer. This requirement places further demands on the receiver technology (which is supposed to be simplified by self-heterodyning) since the LNA must be highly linear in addition to providing high gain and low noise figure. The receiver is accepting a 2-tone input, and the intermodulation products must be kept very low. [2]

In this paper, we propose that a simplified implementation of self-heterodyne detection may be achieved with a hybrid of technologies: traditional self-heterodyne detection assisted by subharmonic down conversion to an IF signal. The concept is illustrated in the system block diagram in Figure 1. The input carrier and modulated signals are first downconverted from 40 GHz to an IF of 1.5 GHz using a fourth-harmonic diode mixer with a 10.375 GHz LO. It may seem contrary to the aims of self-heterodyne detection to introduce an LO when the entire point of the scheme is to eliminate the LO from the receiver. But it will be shown that the requirements for this subharmonic LO are not nearly so strict as it would be for the fundamental LO case, and so the overall receiver simplicity is preserved. The 1.5 GHz IF signals are more easily amplified and filtered than the original millimeter wave signals. After sufficient amplification, they are fed to a final baseband mixer, where the data is recovered.

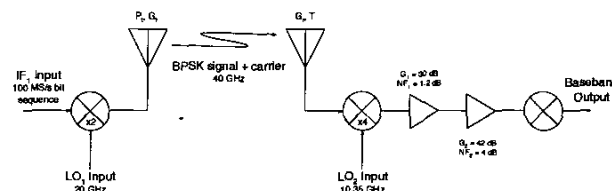

Figure 1 - Receiver model diagram

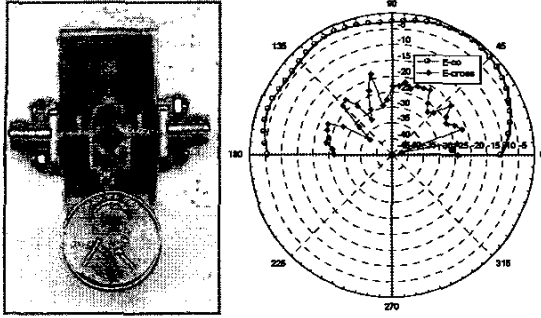

Figure 2 - 40 GHz transmitter with E-plane radiation pattern

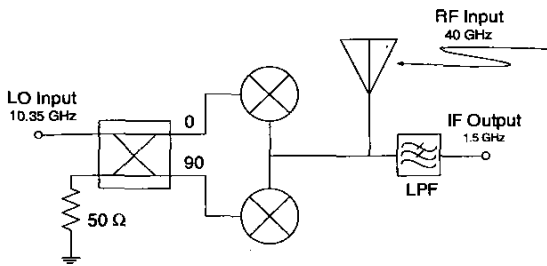

Figure 3 - 4th harmonic mixer using antiparallel diode pairs

II. RECEIVER MODEL AND IMPLEMENTATION

Figure 1 shows the model of our communication link. The transmitter is a simple subharmonic upconverter mixer using an antiparallel diode pair to generate a 40 GHz BPSK signal by mixing the input data stream with the second harmonic of a 20 GHz local oscillator (LO₁). [3] The normally-suppressed carrier was generated by applying a d.c. bias to one arm of the transmitter. LO₁ is provided by an Agilent 83639A synthesized source followed by an Agilent 8349B microwave amplifier, which was used since the transmitter does not feature an integrated power amplifier. The transmitter broadcasts via a single microstrip antenna, resulting in a broad beam. A photo of the transmitter and its radiation pattern is given in Figure 2. The receive antenna was a MACOM Ka-band waveguide horn antenna with a gain of 25 dBi.

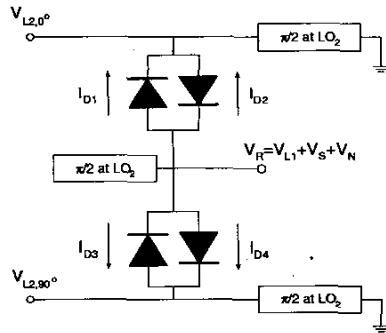

Figure 4 - Mixer diode currents

The fourth harmonic mixer was implemented in two forms. The first, unbiased, mixer, referring to Figure 3, uses two antiparallel diode pairs fed by quadrature phases of the 10.375 GHz LO, supplied by another Agilent 83639A unit. The diodes in each downconverter mixer circuit presented here were Skyworks DMK8001 series GaAs flip chip discrete devices, and both of the fourth harmonic mixers were fabricated on 10 mil thick Duroid 5822 substrate with a dielectric constant of $\epsilon_r=2.2$ and loss tangent of $\tan \delta=0.009$ (The baseband self mixer was fabricated on the same material, with 31 mil thickness). The arrangement of the diodes in the circuit is shown in Figure 4. The short-circuit stubs at the LO inputs are meant to provide an open circuit to the incoming LO signal, and a short circuit to the second and fourth harmonics. Likewise, the open-circuit stub at the RF input presents a short circuit to the LO, and an open to the second and fourth harmonics.

The following analysis will show two important results: The first is verification that the fourth harmonic mixing terms do indeed add in phase at the mixer output. The second is to show that the phase noise of the 10.375 GHz LO signal, designated by $\theta_{L2}(t)$ should not ultimately appear in the final baseband downconverted signal. From Figure 4, the input signals to the mixer are

$$V_{L2,0^\circ} = \sqrt{P_{L2}} \cos(\omega_{L2}t + \theta_{L2}(t)) \quad (1)$$

$$V_{L2,90^\circ} = \sqrt{P_{L2}} \cos(\omega_{L2}t + \theta_{L2}(t) - \frac{\pi}{2}) \quad (2)$$

$$V_R = \sqrt{2P_{L1}} \cos(\omega_{L1}t + \theta_{L1}(t)) + \sqrt{2P_S} \cos([\omega_{L1} + \omega_{RF1}]t + \theta_{L1}(t)) + n(t) \quad (3)$$

The corresponding total diode current is given by

$$I_T = \sum I_{Dn} = -\exp\{V_{L2,0^\circ} - V_R\} + \exp\{-V_{L2,0^\circ} + V_R\} + \exp\{-V_{L2,90^\circ} + V_R\} - \exp\{V_{L2,90^\circ} - V_R\} \quad (4)$$

Since the LO is pumping the mixer at considerable input power, we may assume that the self-product terms of the received carrier and modulated signals are negligibly small. The Taylor series for the exponential terms of (4) produces all possible orders of mixing terms, but we will isolate only the fourth harmonic mixing product terms as being of interest. Other terms are either negligibly small, terminated by the tuning stubs, or otherwise filtered out. The normalized IF output signal is

$$V_{IF2} = 2V_{L2,0^\circ}^4 V_R + 2V_{L2,90^\circ}^4 V_R = 4V_{L2,0^\circ}^4 V_R \quad (5)$$

In each case the negative signs from (4) indicating current direction and voltage polarity always multiply by each other an even number of times so that all terms are positive in the IF. Since both the frequency and phase are multiplied by four when taking the fourth power of the LO signal, the fourth harmonic of the quadrature LO is in phase with the fundamental, and all the mixing terms add constructively. Finally, the components of this secondary IF signal are given in (6-7). Notice that both the received carrier and modulated signals suffer from the phase noise introduced by the LO. But since their phase noise terms are identical, these terms should still cancel at the output if a

square-law detector is used to mix down to basband, as shown in [1].

$$V_{IF2} = \sqrt{2P_{L1}} \cos([\omega_{L1} - 4\omega_{L2}]t + \theta_{LT}(t)) + \sqrt{2P_S} \cos([\omega_{L1} + \omega_{IF1} - 4\omega_{L2}]t + \theta_{LT}(t)) + n_{IF2}(t) \quad (6)$$

$$\theta_{LT}(t) = \theta_{L1}(t) + 4\theta_{L2}(t) \quad (7)$$

The second implementation of the fourth harmonic mixer is shown in Figure 5. This circuit was conceived after recognizing that the diodes in the previous mixer could be biased for optimal performance at lower LO power as long as they were fed in differential quadrature. The hybrid circuit shown in Figure 5 feeds each single-diode mixer with one of four cardinal LO phases.

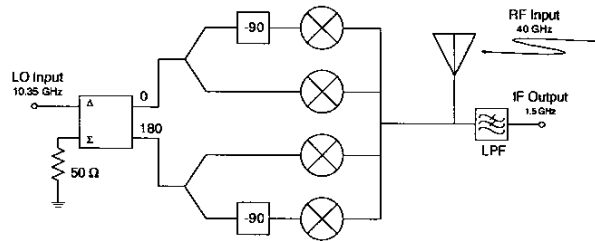

Figure 5 - Biasable 4th harmonic diode mixer

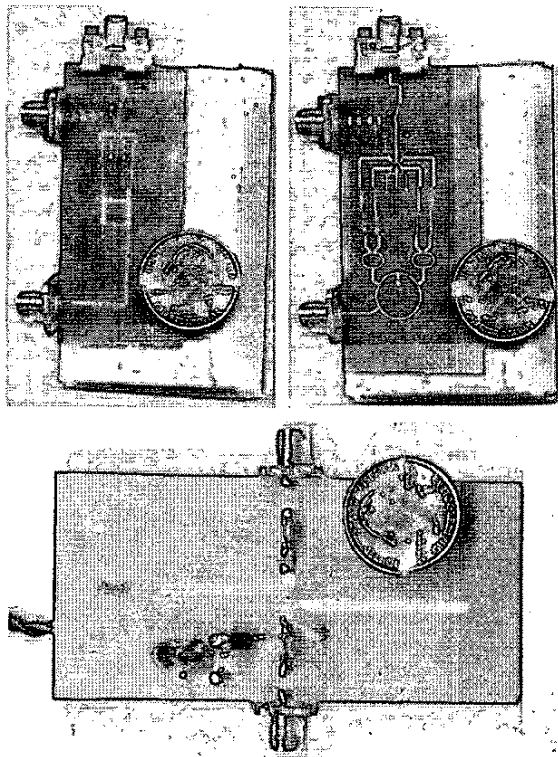

Figure 6 - (a) Unbiased and (b) biasable 4th harmonic diode mixers (c) self mixer for demodulation

The IF amplifier chain is made up of two packaged amplifiers: The first is a Miteq AFS3 series LNA with 30 dB of gain and NF<1.2 dB at 1.5 GHz. The second is an Avantek SSF86 series with 45 dB of gain and NF<4 dB at 1.5 GHz. The overall gain and noise figure are G=75 dB and NF<1.21 dB

The final component in the signal path is the self-mixer for converting the received signals down to baseband. A simple single diode mixer was used for this purpose. The analysis in [1] indicates that a square-law detector is necessary for phase noise cancellation during self-mixing. While a single diode is not strictly a square-law device, its output harmonics do contain the same second-order mixing terms as for a square law device. Therefore, the first and third order mixing products were terminated in the design of the mixer to allow the square law products to pass through. Figure 6 shows photographs of all three mixer circuits.

III. MEASUREMENT RESULTS

The 4th harmonic diode mixer performance is shown in Figure 7. The conversion efficiency of the first, unbiased mixer saturates at a low input power of 6 dBm, or 4 mW. The biasable mixer shows comparable conversion loss at the even lower input power level of 0 dBm, or 1 mW, given 450 mV (0.72 mA) of d.c. bias. This is a remarkable improvement considering the the LO power in the biased mixer is split between four devices, compared to only two in the unbiased mixer.

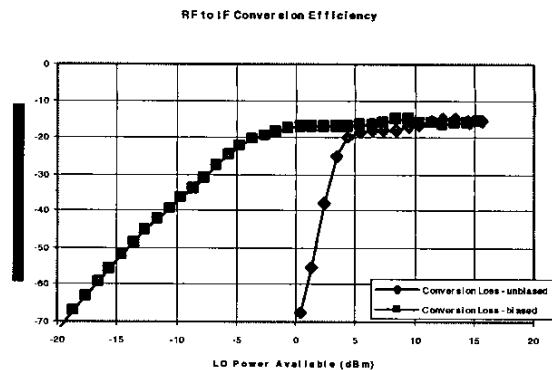

Figure 7 - Conversion loss for both 4th harmonic mixers

Figure 8 shows the IF input and output time-domain waveforms. The input is a 100 MS/s preprogrammed bit sequence, and is the upper waveform in the plot. The lower waveform is the output of the self mixer. Although the binary values of the output are a bit noisy, the zero crossings clearly map in a one-to-one correspondence between the input and output IF signals. The transmission distance was 2 meters, and the transmitter power was +10 dBm.

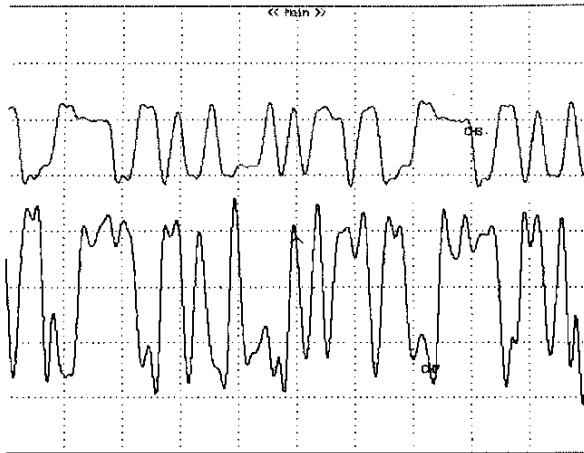

Figure 8 - Time domain plot of input and output IF waveforms

The phase noise of the input and output IF signals were measured with an Agilent 8565 spectrum analyzer using the noise offset marker function. The IF input in this case was a simple 10 MHz sine wave, and not a bit sequence, to allow for ease in measuring the phase noise. It was found that for carrier offsets less than 100 kHz, the phase noises of the input and output signals were identical. This satisfies the prediction that the phase noise of the two LO signals should cancel out at the time of direct down conversion to baseband. Beyond 100 kHz offset from the carrier, the phase noise of the two IF signals are not the same, indicating that phase noise cancellation is no longer taking place. This is likely due to the finite bandwidth over which the baseband diode mixer functions as a square law device. This deviation from predicted performance certainly deserves further investigation.

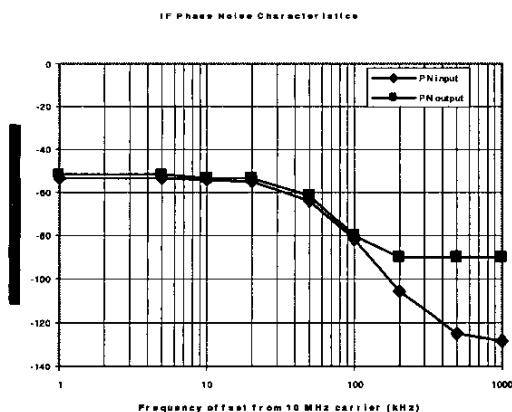

Figure 9 - Phase noise of input and output IF carriers

IV. CONCLUSIONS

The concept of IF-assisted self-heterodyne detection is very simple, but highly practical. As can be seen from the conversion loss and phase noise measurement results, the addition of an LO to the receiver would not increase its complexity very much since the LO would not have to perform to a very high standard.

Using a biased 4th harmonic diode mixer, the LO would have to output about 1 mW of power at ¼ of the transmitted frequency. In addition, it can be a noisy oscillator without really affecting the phase noise of the output signal.

Down conversion to a low frequency microwave IF signal allows more sophisticated filtering and amplification than would otherwise be available at the transmitted carrier frequency. In this work, the conversion loss of the diode mixers, as well as the free space loss of transmission were more than compensated by the gain of the IF amplifier chain. It would be difficult to impossible to arrange for 75 dB of gain with such a low noise figure at the transmitted frequency of 40 GHz.

REFERENCES

1. Yozo Shoji, K. Hamaguchi, H. Ogawa, "Millimeter-wave remote self heterodyne system for extremely stable and low-cost broad band signal transmission," *IEEE Trans Microwave Theory Tech*, Vol. 50, No. 6, June 2002, pp. 1458-1468.
2. J. Park, Y. Wang, T. Itoh, "A microwave communication link with self-heterodyne direct down conversion and system predistortion," *2002 IEEE MTT-S Int. Microwave Symp. Dig.*, vol. 2, pp. 939-942, June 2002.
3. J.Y. Park, S.S. Jeon, Y. Wang, T. Itoh, "Millimeter wave direct quadrature converter integrated with antenna for broadband wireless communications," *2002 IEEE MTT-S Int. Microwave Symp. Dig.*, vol. 2, pp. 1277-1280, June 2002.
4. Stephen A. Maas, *Nonlinear Microwave Circuits*, Norwood, MA: Artech House, Inc., 1988.
5. L.W. Couch, *Digital and Analog Communication Systems, 5th ed.*, New Jersey: Prentice Hall, 1997.